

# Mechanical accessories

## 1. Brackets for ELEKTROMATEN SI + SIK

### 1.1 Bracket

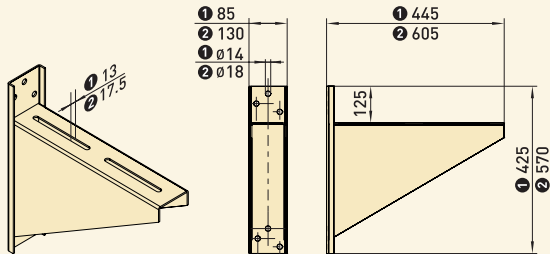

For Series	Part no.	Max. load
SG63F / SG63F-SIK SG85F (≤ SI 55)	① 40006488	5 kN
SG115F (≤ SI 140)	② 40012396	12 kN

### 1.2 Bracket

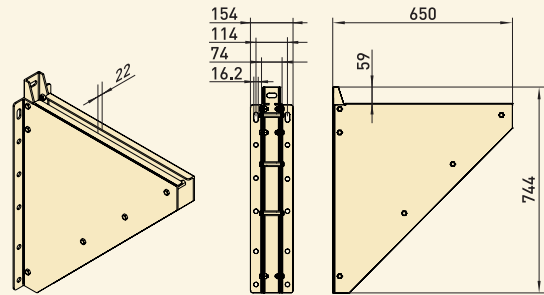

For Series	Part no.	Max. load
SG115F (≥ SI 180) SG186F	40016189	29 kN

## 2. Brackets for ELEKTROMATEN KE

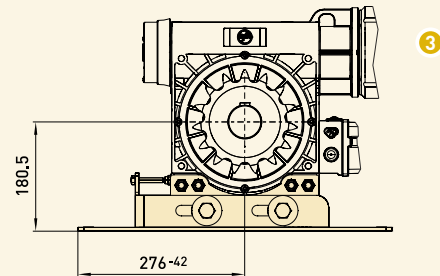
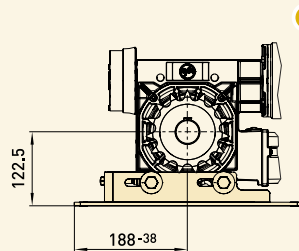
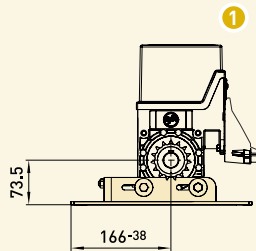
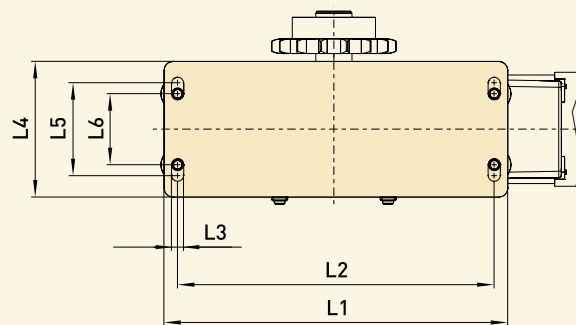
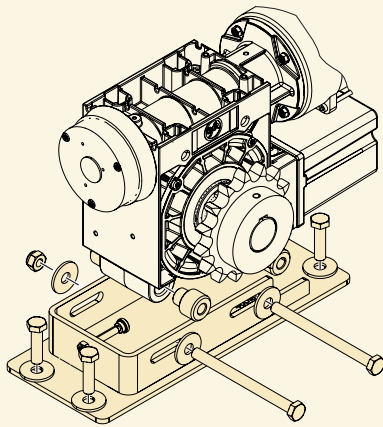

For Series	Part no.	L1	L2	L3	L4	L5	L6
① SG50	30005056	300	258,5	11,5	130	103,5	76,5
② SG85	30005055	380	350	13,5	150	101,5	78,5
③ SG115	30005100	520	485	17,5	200	112,5	87,5

■ Mounting without foot angles

# Mechanical accessories

## 3. Torque mount for series SG40

### 3.1 Torque bracket SG40 Type A

Part no. 30005807

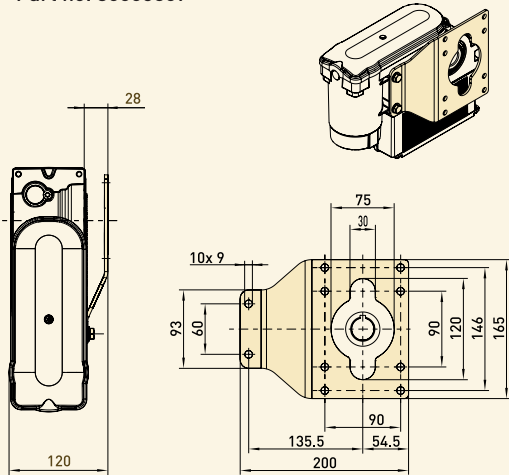

■ ELEKTROMATEN horizontal only

### 3.2 Torque bracket SG40 Type B

Part no. 30005808

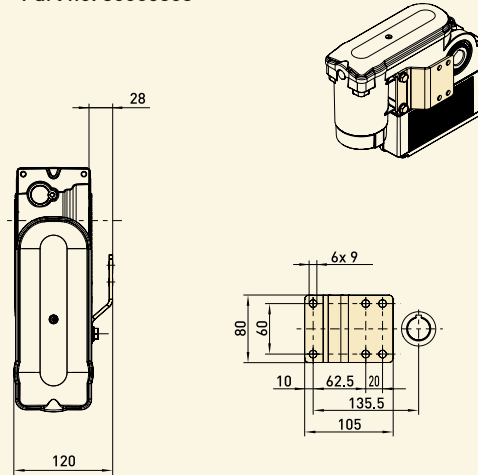

■ ELEKTROMATEN horizontal only

## 4. Torque mount + Flange bracket for series SG50

### 4.1 Torque bracket

Part no. 30002636

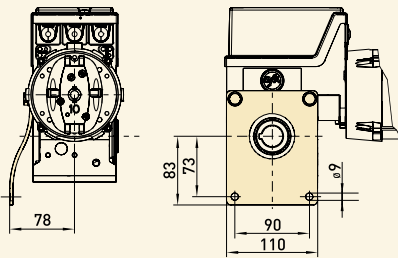

### 4.2 Flange bracket H 107-125

Part no. 30002685

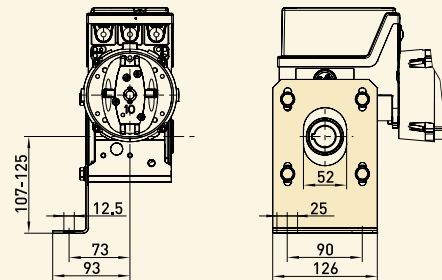

### 4.3 Flange bracket H 80-190

Part no. 30005839

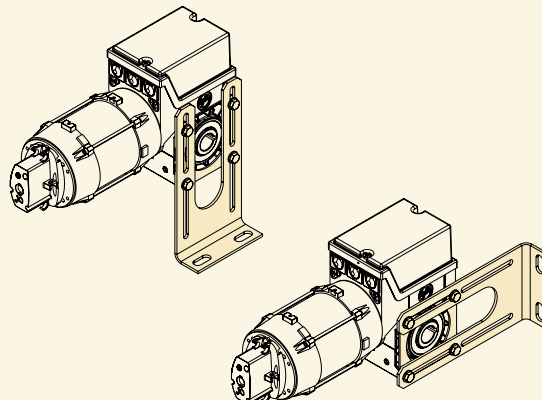
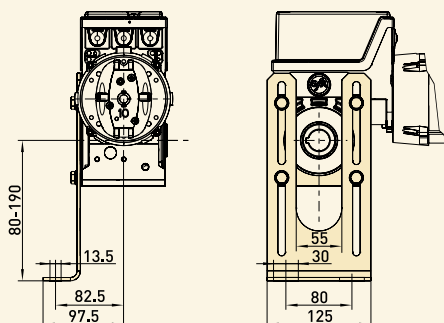

■ All brackets can be mounted vertically or horizontally

# Mechanical accessories

## 5. Torque mount for series SG63 up to SG115

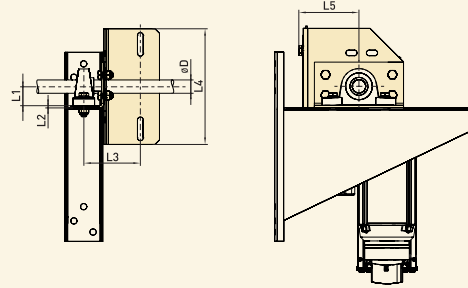
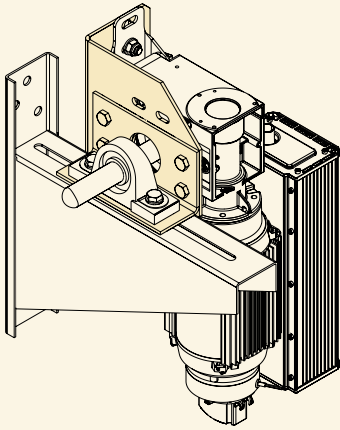

For Series	Ø D	Part.-no.	L1	L2	L3	L4	L5
SG63F	25	30002930	36,5	5	127	260	135
SG63F / SG85F	30	30002930	42,9	5	127	260	135
SG85F	40	30002930	49,2	5	127	260	135
SG115F	55	30003162	63,5	6	174	350	148
SG115F	60	30003162	69,8	6	174	350	148

- Right- or left-hand use
- For mounting with floating foot additional requirements: Bracket 1.1 or 1.2 and bearing
- ELEKTROMATEN vertical (as shown) or horizontal (for vertical mounting, FI-motors has to be turned by 90°)

## 6. Moving-torque mount for series SG63F-SIK

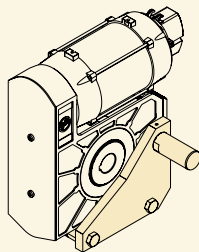

Part no.:  
20002773.00005

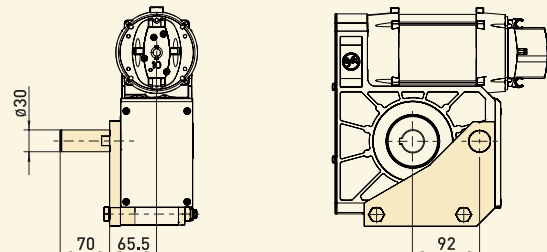

- Right- or left-hand use
- ELEKTROMATEN horizontal only

## 7. Moving-torque mounts for series SG63 up to SG115

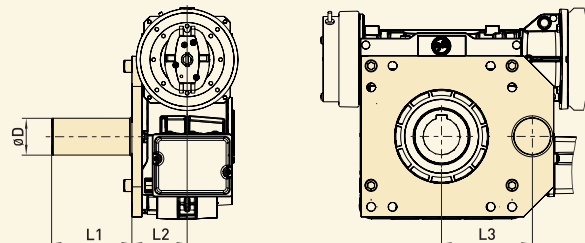
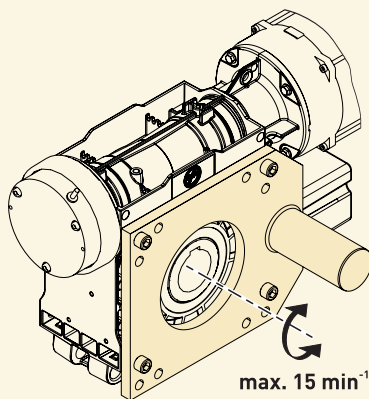

Series	Ø D	Part no.	L1	L2	L3
SG63F <sup>1)</sup>	30	20002641.00004	70	72,5	95
SG85F	30	20002494.00024	80	70	105
SG85F	40	20002494.00025	80	70	105
SG115F <sup>2)</sup>	55	20002495.00004	120	83	135

- Right- or left-hand use
- ELEKTROMATEN horizontal (as shown) or vertical

- 1) Special version of ELEKTROMATEN with side thread is required
- 2) No use with SI 180.6