

ELEKTROMATEN® SI

Safedrive®

For driving:
Roller shutters and rolling grilles
which require an anti-fallback device

Series SG186F
SI 260.5 - SI 500.5 GH

“Safedrive® FI” ELEKTROMATEN SI are special drives for industrial doors which require an anti-fallback device. The patented safety brake is built into the gear. The drive unit is fitted directly to the door shaft. Safedrive® ELEKTROMATEN comprises of:
Worm gear with safety brake and hollow shaft, emergency manual operator, integrated limit switches and electrical motor.

Patented built-in safety brake

- Safety against failure of worm or wheel
- Independent of speed / direction
- Maintenance free, self-monitoring
- Excellent damping characteristics in operation

Approvals and certificates

ELEKTROMATEN

Type test according to:
DIN EN 12453
DIN EN 60335-1
DIN EN 60335-2-103
TÜV NORD CERT GmbH



Built-in safety brake

Certificate of conformity according to:
DIN EN 12604 / 12605
ift Rosenheim GmbH



1

Emergency manual operation

- Hand chain operator KNH

1



2

Limit switches

Mechanical limit NES

- 2 operating, 2 emergency- and 2 auxiliary limit switches

2

Digital limit DES

- Absolute encoder, after a power failure, re-adjustment is not required

3



3

Mounting

- Floating foot (standard fitting)

Special versions

- Increase of cycles per hour
- Higher protection class
- Other voltages and frequencies
- ELEKTROMATEN SI with built-on frequency inverter (page 1.121)

Door controls

- Simple connection by means of non-interchangeable plug connections allowing simple exchange with other GfA control panels
- Control voltage: 24 V
- Frequency: 50 Hz / 60 Hz
- Mains supply: 3~230 V, 3N~400 V, 3~400 V

Details of all GfA door controls can be found in Section 8.

1. Technical data

ELEKTROMATEN Series		SI 260.5	SI 260.9	SI 360.5	SI 360.9	SI 480.9	SI 500.5 GH
		SG186F	SG186F	SG186F	SG186F	SG186F	SG186F
Output torque	Nm	2600	2600	3600	3600	4800	5000
Output speed	rpm	5	9	5	9	9	5
Output shaft / hollow shaft (Ø)	mm	80	80	80	80 / 100	100	100
Locking torque ¹⁾	Nm	8255	8255	8255	8255	8255	8255
Safety brake (approval number)		16-000574-PR03	16-000574-PR03	16-000574-PR03	16-000574-PR03/PR01	16-000574-PR01	16-000574-PR01
Max. holding torque ²⁾	Nm	2600	2600	3600	3600	4800	5000
Max. output speed OPEN / CLOSE for frequency inverter operation ³⁾	rpm	5 / 5	9 / 9	5 / 5	9 / 9	9 / 9	5 / 5
Motor power	kW	1,5	3,0	2,0	3,0	3,0	2,5
Supply voltage	V	3-230 / 400	3-230 / 400	3-230 / 400	3-230 / 400	3-230 / 400	3-230 / 400
Operating frequency	Hz	50	50	50	50	50	50
Operating current ⁴⁾	A	6,7 / 3,9	11,9 / 6,9	8,6 / 4,7	11,9 / 6,9	11,4 / 6,6	10,0 / 5,8
Max. cycles per hour ⁵⁾		9 (2,9)	10 (5,2)	9 (3,5)	10 (5,2)	10 (5,2)	9 (3,5)
Limit switch range ⁶⁾		10	10	10	10 (30)	10 (30)	10 (30)
Max. hand force KNH ⁷⁾	N	182	182	215	215	255	261
Weight	kg	123	128	125	127	130	129
Part no. installation drawing (dxf, dwg)		50001996	50001996	50001996	50001996	50001996	50001997
Part no. ELEKTROMATEN		Ø 80 10005218	Ø 80 10005217	Ø 80 10005216	Ø 80 10005215 Ø 100 10004323	Ø 100 10004324	Ø 100 10004344

Generally applies: IP65, permissible temperature range -10 °C...+40 °C (+60 °C), operating sound pressure level SPL <70 dB(A)

1) See 3.5 · 2) Maximum torque that may act on the output shaft of the drive unit when the door is stationary · 3) We recommend the selection of GfA ELEKTROMATEN-FI for use with frequency inverter, OPEN drive speed at 87 Hz, see 3.7 · 4) The operating current in door drives can reach up to 4x the rated current for limited periods, see 3.6 and 3.7 · 5) One cycle consists of a complete opening and closing movement of the door. The value according to EN 60335-2-103 is given in brackets. If the limit switch range is not fully used, the number of possible cycles can be increased in relation to the reduced number of revolutions of the output shaft, see also 3.2 · 6) Maximum revolutions of hollow shaft · 7) See 3.4

2. Selection chart

Roller shutters Tube EN 10220 [mm]	SI 260			SI 360			SI 480.9		SI 500.5 GH	
	F [N]	v _a [cm/s]	v _a [cm/s]	F [N]	v _a [cm/s]	v _a [cm/s]	F [N]	v _a [cm/s]	F [N]	v _a [cm/s]
298,5 x 7,1	11429	8,3	15,0	15824	8,3	15,0	--	--	--	--
323,9 x 7,1	10584	9,0	16,2	14655	9,0	16,2	19541	16,2	20355	9,0
368,0 x 8,0	9381	10,2	18,3	12990	10,2	18,3	17320	18,3	18041	10,2
406,4 x 8,8	8537	11,2	20,1	11820	11,2	20,1	15760	20,1	16417	11,2
419,0 x 10,0	8292	11,5	20,7	11481	11,5	20,7	15308	20,7	15945	11,5
457,2 x 10,0	--	--	--	--	--	--	14082	22,5	14669	12,5
508,0 x 11,0	--	--	--	--	--	--	12727	24,9	13258	13,8

■ F = Lift [N]

■ v_a = Initial speed [cm/s]

■ Includes 30 % friction for single-wall profiles (profile thickness 20 mm)

■ Read note in 3.2

3. Notes

3.1 European directive

In accordance with the product standard EN 13241 Doors- and EN 12453 Safety in use of power operated doors-Requirements.

3.2 Selection chart / Cycles per hour

The specified cycles per hour (see technical data) apply to even distribution and the limit switch range first mentioned. When using the temperature range +40 °C to +60 °C, the specified value must be halved. For other limit switch ranges, the values must be converted accordingly.

The selection chart includes 30 % friction for roller shutters with single-wall profiles (profile thickness 20 mm) and 10 % friction for sectional doors.

Reduce the weight by a further 20 % for vertical lifted doors and insulated shutters with double walled, thick and/or deep sections. Do not calculate using the tube diameter. The highest torque will occur normally after 1-2 turns of the barrel from close.

3.3 Gear self-braking / Brake

Drives without an electric brake have a self-sustaining worm gear and stop automatically.

On drives with an electric brake, stopping is achieved by the external brake. Brake inspection must always be carried out by qualified service engineers.

3.4 Manual operation

In accordance with EN 12453 and 12604 hand force up to 390 N is permissible. For large, heavy doors, manual operation is only used for closing the door. In the case of drive units with an electric brake; emergency manual operation is carried out against the closed brake (Read note in 3.3).

3.5 Locking torque / Holding torque

The permissible loads on walls, fastenings, mountings and transmission elements must not be exceeded, even for maximum holding torques or locking torques.

3.6 Motor overload protection

Motor overload protection must be able to withstand 4x the operating motor current because the starting current of the drive unit can reach these levels for short periods.

3.7 Use with external frequency inverter

We recommend ELEKTROMATEN FI with an integrated frequency inverter (page 1.121).

For external frequency inverters applies:

A higher than recommended drive speed puts extra load onto the gear. This extra load must be taken into account when sizing a drive by reducing the available output torque.

Increasing the drive speed by 10 % reduces the admissible drive torque by 5 %. In the case of higher drive speeds reduce the drive torque accordingly (enquire if necessary).

The admissible drive speeds may not be exceeded (see Technical data). The operating forces must comply with EN 12453, and the corresponding EMC directives must likewise be observed.

If selecting a frequency inverter, note that the starting current of the drive unit can reach 4x the operating motor current.

3.8 Cable / Cable drums

When calculating the cable size the max. permitted door weight is required with a safety of 6x for the cables requirement of EN 12604.

Cable drum selection – ensure that two turns of the cable remain on the drum at all times. The diameter of the cable drum must be at least 20x the diameter of the cable.

4. Dimensions

4.1 SI 260.5 – SI 480.9

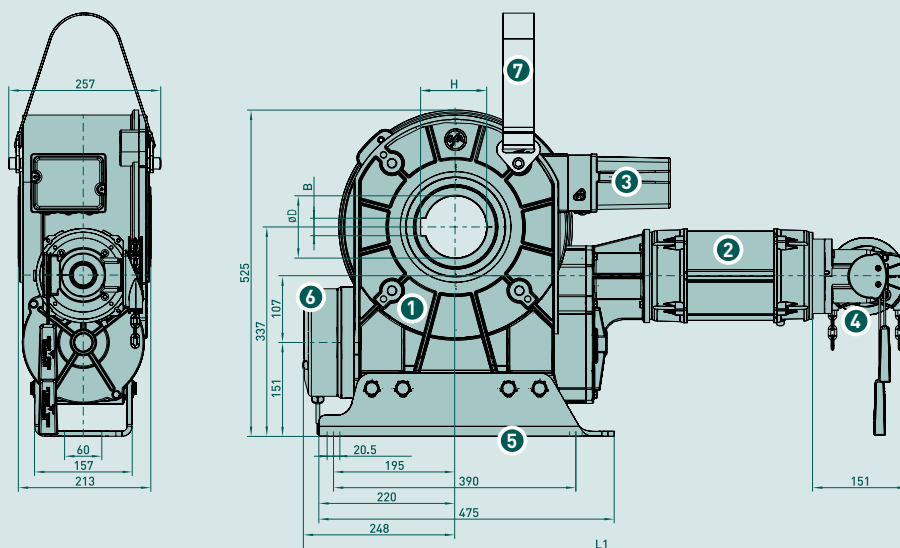

SG186F

- 1 Worm gear with safety brake
- 2 Motor
- 3 Limit switch
- 4 Emergency manual operation KNH
- 5 Floating foot
- 6 Brake
- 7 Assembling aid

Ø D	H	B
80	85,4	22
100	106,4	28

ELEKTROMATEN	L1
SI 260.5	897
SI 260.9	942
SI 360.5	922
SI 360.9	942
SI 480.9	972

■ Permitted installation: Horizontal with an additional torque mount system, see 6

4.2 SI 500.5 GH

SG186F

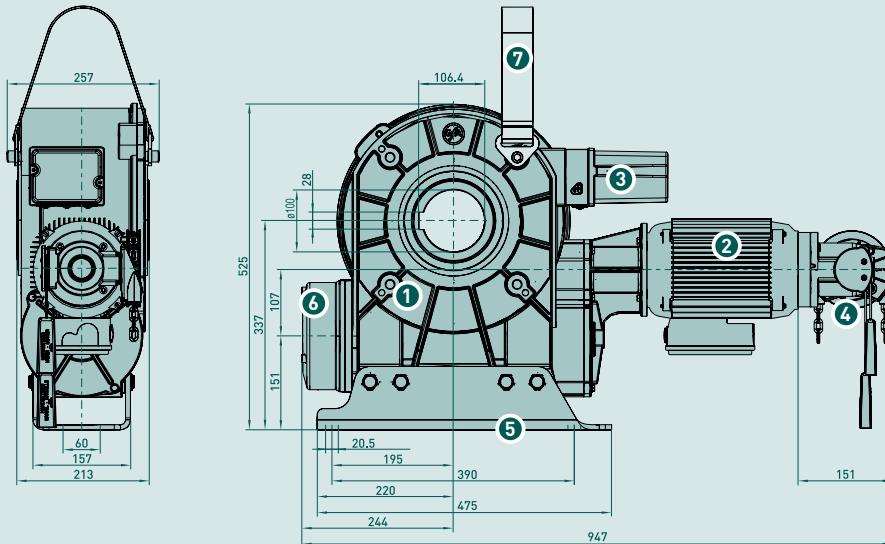

- 1 Worm gear with safety brake
- 2 Motor
- 3 Limit switch
- 4 Emergency manual operation KNH
- 5 Floating foot
- 6 Brake
- 7 Assembling aid

■ Permitted installation: Horizontal with an additional torque mount system, see 6

5. Emergency manual operation • for horizontal installation

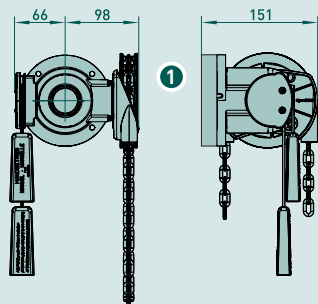

- 1 Hand chain operator KNH

■ Manual forces, see item 1 of technical data

■ Read note in 3.4

6. Attachments / Accessories

Bracket

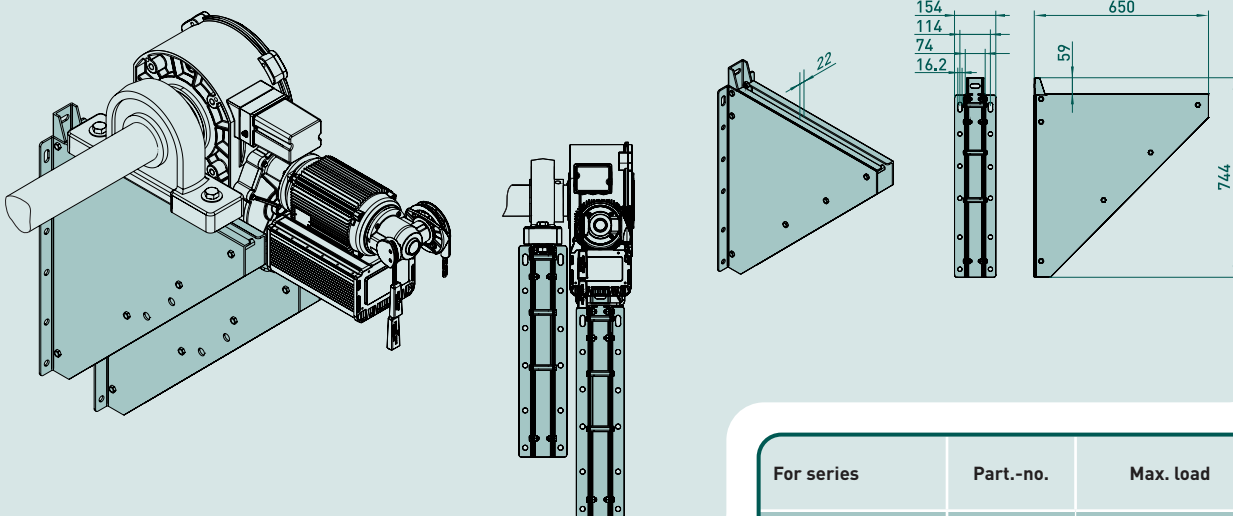

For series	Part.-no.	Max. load
SG186F	40016189	29 kN

■ Mounting of the door shaft via separate bearing
 ■ 2nd bracket as a torque mount is required

■ Permitted installation: Horizontal